



# IPG D33 High Power Scanner



# D33 High Power Scanner

IPG D33 2D High-Power Scanners are industry-leading remote laser welding solutions with **up to 12 kW of continuous wave laser power** handling that is the highest power handling capabilities of any scanner in its class. This allows for greater weld penetration and increased travel speeds, which translates to increased productivity and reduced costs.

As the world leader in fiber laser technology, IPG understands that no two applications are the same. Offering **various optical combinations and the ability to interface with any series IPG laser** (YLS, YLS-AMB, YLR, YLPN), users can easily tailor the equipment to the process. The IPG customized interface between the scanner and the laser allows for easy integration and complete process control. Additionally, the scanner-integration-center provides users with all the necessary connections for seamless integration into an automated system.

Welding processes are quickly and easily created with IPGScan software. Manufacturers can efficiently setup **on-the-fly** or **point-and-shoot** processes to optimize product throughput. Additionally, various interfaces, including Fieldbus (Ethernet/IP, ProfiNet, EtherCAT), are available to automate the system and provide software and hardware status for complete control over the process.

When combined with the IPG patented LDD process monitoring technology, manufacturers can rest assured that parts coming off of the production line are of the **highest possible quality**.

IPG D33 2D High-Power Scanners provide **tailored solutions, easy integration, and powerful programming functionality, with reduced overall costs**.

## IPGScan Software

### NO SOFTWARE LICENSES

Eliminate excessive license and renewal fees with IPGScan remote scanning software, which is available for download at any time.

### PROCESS VISUALIZATION

By importing STL models, users can create realistic process simulations in IPGScan. This functionality allows users to develop precise process timings and ensure beam angles will not clip expensive fixturing.

### ON-THE-FLY LASER WELDING

Advanced timeline functionality allows users to reduce process cycle time by providing detailed process timings & easy to use tools for making process parameter changes.



**Industrial Design**  
Designed for the most rugged environments, 2D High-Power Scanners feature industrial IP67 tested enclosures



**Industrial Connectors**  
Plug and play architecture utilizing industrial connectors allows for quick installation and easy integration

### Contamination Detection

Protect the process and equipment with an integrated sensor for Protective Window contamination sensing

### Quick Exchange Window Assembly

Reduce production down-time for Protective Window change-out thanks to the quick exchange Window Assembly design

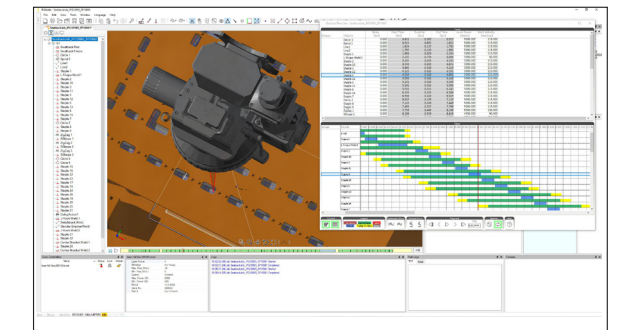

IPGScan Process & Timing Visualization

## CONFIGURE REMOTE LASER WELDING APPLICATIONS IN MINUTES

IPGScan is a powerful software suite that provides users with process parameters specifically tailored to the application and laser being utilized. Within IPGScan, users have the ability to **import CAD models, place process objects** (e.g. welds), **create simulated motion paths, and optimize process timings** using advanced timeline functionality.

Graphical display of the laser beam emitting from the scan head helps to ensure that expensive fixturing will not be clipped by the beam. These powerful features enable users to visualize the complete process before equipment ever hits the shop floor. When equipment is set up, users can **easily transition from programming in the offline world to the real world with a few quick calibrations**. Loaded with powerful software features, IPGScan allows users to develop complete process solutions while reducing overall costs.

## Specifications

Compatible Laser Series	YLS, YLS-AMB, YLR, YLPN					
Max Multi-Mode CW Power (kW)	12.0					
Max Single-Mode CW Power (kW)	4.0					
Available Fiber Adapters	HLC-8, HLC-8 with Rotary, HLC-16, LCA					

## Optical Specifications

Wavelength (nm)	1065 – 1075					
Clear Aperture (mm)	33					
Focus Lens Name	F254 MM	F405 SM	F413 MM	F510 MM	F500 SM	F505 SM
Focal Length (mm)	254	405	413	510	500	505
Nominal Working Distance (mm)	261	510	415	530	608	635
Square Field Size ([X]mm x [Y]mm) <sup>1</sup>	110 x 110	200 x 200	200 x 200	250 x 250	250 x 250	270 x 270
Galvo Long-Term Drift (μm) <sup>2</sup>	<30	<50	<50	<60	<60	<60
Galvo Positioning Repeatability (μm) <sup>3</sup>	<8	<12	<12	<15	<15	<15
Collimator Options (mm)	100, 120, 140, 150, 160, 180, 200					

## Mechanical Specifications

IP Rating	IP67					
Scanner Dimensions [LxWxH] (mm) <sup>4</sup>	317 x 190 x 357					
Scanner Weight (kg) <sup>4</sup>	11.3-14.0					

## Available Accessories

Linear and Circular Air Knife	For Spatter and Process Control					
Through the Lens Vision Cameras	Ethernet, HDMI					
Integration Control Center	Complete solution containing power supplies, Scanner Fieldbus Interface, and appropriate cables					

## External Interfaces for Automated Systems Integration

Scanner Fieldbus Interface	Supported Protocols: Ethernet/IP, ProfiNet, EtherCAT					
Extended IO	Discrete IO Interface: 19 Digital Inputs, 16 Digital Outputs					
Motion Interface	For motor control or encoder feedback Capable of single-ended or differential signal feedback					

1. Rectangular fields of view are available for some lens configurations

2. Long-term drift with constant ambient conditions after the readiness for operation (heat-up time). Both galvos considered

3. Both galvos considered

4. Assuming 2D High Power Scanner with 510 mm focal length, 120 mm collimator, LCA fiber adapter, and without LDD, camera, or air knife attachments



+1 (508) 373-1100;

[IPGPhotonics.com/contact](https://www.ipgphotonics.com/contact)

[www.ipgphotonics.com](https://www.ipgphotonics.com)

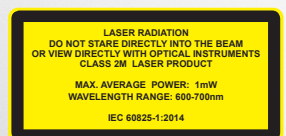

**Legal notices:** All product information is believed to be accurate and is subject to change without notice. Information contained herein shall legally bind IPG only if it is specifically incorporated into the terms and conditions of a sales agreement. Some specific combinations of options may not be available. The user assumes all risks and liability whatsoever in connection with use of a product or its application. IPG, IPG Photonics, The Power to Transform and IPG Photonics' logo are trademarks of IPG Photonics Corporation. © 2024 IPG Photonics Corporation. **All rights reserved.**