

Tip Dresser & Changer (powered by 3-Phase AC Motor)

XCD



※ Magazine is optional product.

Feature

- Available for both dressing / changing with single motor.
- Cylinder brake is attached on remove unit.
Strong grab for tip removal.
- Powered by compact 3-phase AC motor which has high power, high speed.
- Compact design for both ATC / ATC by mounting the motor vertically.
- Highest removable force (tip turning force) among Kyokutoh products.

System 1

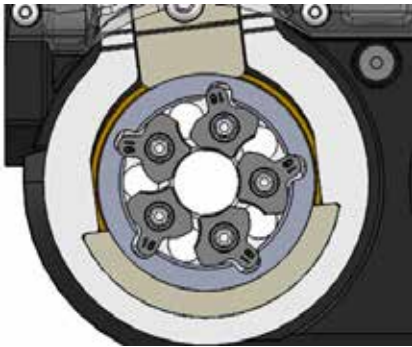

- Forward/Reverse rotating nails, Shank adapter pullout prevention
- Strong removal torque

System 2

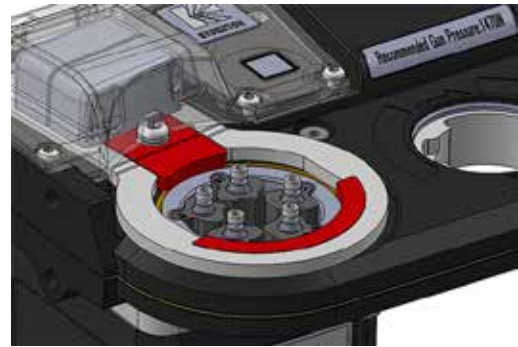

- Strong removal performance by cylinder and brake
- Brake is made of resin material for long life and stable performance

Magazine

STC

XR



- Light & Compact
- Good cost performance
- Available for various types of cap tip
- Easy teaching just by applying pressure

Simple specifications

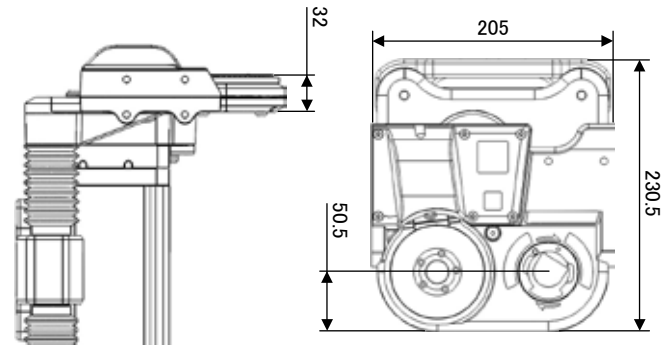

Weight: 17.2kg (without magazine)

Rotation speed: 404rpm (Dress-side 200V 60Hz)

※ Specification and design are to be changed without notice for improvement.